

The nmr spectrum of the hydrocarbon mixture exhibited a triplet at τ 7.72 (ArCH_3), a singlet at 6.95 (CH_2 protons in **11**), complex absorptions from 4.0 to 5.1 (olefinic H in **10**), and a multiplet from 2.8 to 3.2 (Ar-H). Analysis by nmr methods revealed the mixture to be 69% **10** and 31% **11**. By gas-liquid chromatography the mixture was found to be 67% **10** and 33% **11**.

Thermal Decomposition of (2,6-Dimethylphenyl)diazomethane (13). Decomposition of **13** was effected gas-liquid chromatographically in an injector at 194° and on a Carbowax 20-M column at 178°. The low boiling products were 3-methylstyrene (**12**, 3%), 3-methylbenzocyclobutene (**15**, 17%), 2,6-dimethylbenzocyanide (7%), and 2,6-dimethylbenzyl alcohol (1%).

The hydrocarbon product was preparatively collected as a mixture and revealed an ultraviolet absorption maximum at 251 $m\mu$ which corresponded to that of authentic **12**. The mixture displayed olefinic absorption at 6.2 μ and cycloalkane absorption at 10.05 μ . Strong absorptions were obtained at 12.7 and 14.1 μ corresponding to those in the spectrum of authentic **12**; absorptions characteristic of 2-methylstyrene (**16**) at 13.0 and 13.7 μ were absent.

The nmr spectrum of the mixture showed singlets at τ 7.92 and 7.77 (ArCH_3), a singlet at 7.01 (CH_2 protons in **15**), complex absorptions from 4.0 to 5.0 (olefinic protons in **12**), and a multiplet at 3.2 (ArH). Integration of the olefinic and the methylene hydrogen resonances indicated that the product was 7% **12** and 93% **15**. Analysis of the mixture chromatographically on a 100-ft squalane column at 58° indicated that 13% **12** and 87% **15** were present; there was no evidence for formation of **16** in these experiments.

Thermal Decomposition of the Sodium Salt 32 of α -Deuterio-2-methylbenzaldehyde Tosylhydrazone (31). α -Deuterio-2-methylbenzaldehyde was converted to **31** by tosylhydrazide in tetrahydrofuran and then to **32** by sodium hydride in anhydrous diethyl ether. Decomposition of dry **32** was effected at 350° using the hot tube techniques previously described. The volatile product was shown to be **6** and **7** in a 1:3 ratio by analytical gas-liquid chromatography. The hydrocarbons were separated and collected using a gas-liquid chromatographic column of tetracyanoethylated pentaerythritol (20%) on Chromosorb P (80%) at 80°. The location of deuterium in **35** and **36** was revealed by their nmr spectra (see Figure 1 and previous discussion).

Authentic 2-Deuteriostyrene (35). The reaction of pure 2-bromo-toluene with magnesium in anhydrous diethyl ether and decomposition of the resulting Grignard reagent with 99.5% deuterium oxide yielded 2-deuteriotoluene. Oxidation of the 2-deuteriotoluene with chromyl chloride³⁰ and hydrolysis of the subsequent adduct gave 2-deuteriobenzaldehyde (50%) which was converted to 1-(2-deuteriophenyl)-1-ethanol by reaction with methylmagnesium bromide in diethyl ether and hydrolysis. Dehydration of the deuterated alcohol to **35** was accomplished by adding a drop of sulfuric acid, heating the mixture, and distilling away the volatile product.

(30) H. Law and E. Perkin, *J. Chem. Soc.*, **91**, 258 (1907).

Bond-Stretch Isomerism and Polytopal Rearrangements in $(\text{CH})_5^+$, $(\text{CH})_5^-$, and $(\text{CH})_4\text{CO}$

Wolf-Dieter Stohrer and Roald Hoffmann*

Contribution from the Department of Chemistry, Cornell University, Ithaca, New York 14850. Received June 21, 1971

Abstract: Following a general outline of the theoretical prerequisites for creating a double energy minimum upon simple stretching of a single bond we present an analysis of one such case, the tricyclo[2.1.0.0^{2,5}]pentane system. The 3-carbonium ion of this molecule exhibits a clear double minimum upon stretching the central bicyclobutane bond, created by interaction of the carbonium ion p orbital with a σ^* level. The resulting $(\text{CH})_5^+$ potential surface shows typical Jahn-Teller behavior—open and closed C_{2v} minima circumventing a D_{3h} structure. The C_{2v} structures, as well as other $(\text{CH})_5^+$ isomers, appear to be unstable with respect to a square pyramidal C_{4v} cation. The quantum mechanical calculations allow a qualitative evaluation of the energy barriers to various polytopal rearrangements of this species, as well as of $(\text{CH})_5^-$. A similar case of bond-stretch isomerism is predicted for $(\text{CH})_4\text{CO}$, whose rearrangements are more inhibited than those of $(\text{CH})_5^+$.

Awareness of orbital symmetry constraints on chemical reactions permits one to make a qualitative judgment as to the relative stabilities of molecules with respect to the reactive channels open to them. Highly strained molecules, such as Dewar benzene or bicyclo[2.1.0]pentene, owe their relative stability to the fact that a forbidden reaction, a change in predominant electronic configuration, separates them from their geometrically close and thermodynamically much more stable isomers.¹ In further development of these ideas, we have been exploring a novel type of isomerism in which two or more stable conformations of a molecule related to each other by a simple bond stretching differ in their electronic configurations.

Consider the consequences of stretching a normal single bond, described by a symmetric (S) σ level and an antisymmetric (A) σ^* level. As the interatomic

separation increases from the equilibrium value, the S and A levels approach each other. The ground state of the system is adequately described by the configura-

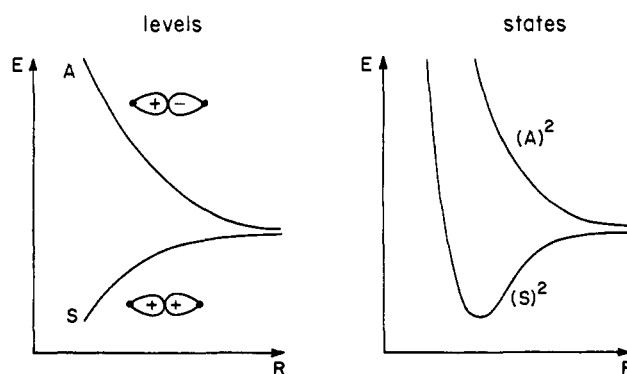

1

(1) R. B. Woodward and R. Hoffmann, *Angew. Chem.*, **81**, 797 (1969).

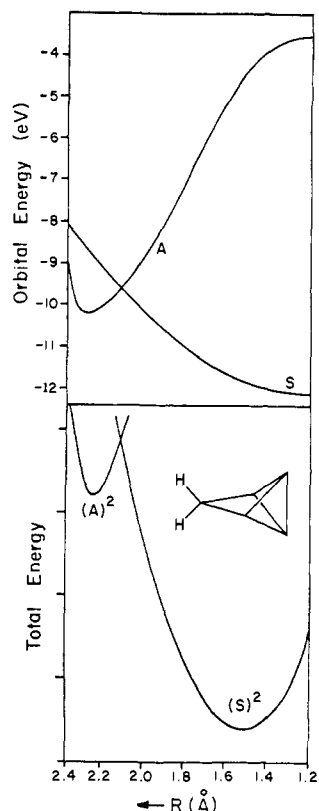
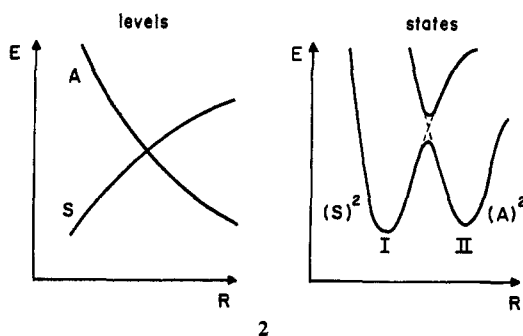

Figure 1. HOMO and LUMO (top) and configuration energies (bottom) for stretching the 1-5 bond in tricyclo[2.1.0.0^{2,5}]pentane. R is the 1-5 bond distance. The total energy scale interval is 1.0 eV.

tion (S)².² There is only one minimum, only one bond-stretch isomer.

The alternative situation, exhibiting what we may tentatively call bond-stretch isomerism, occurs when S and A cross as a function of R . The lowest energy configuration at short R is (S)², at longer R , it is (A)².



The ground state of the system may be described as $c_1(S)^2 + c_2(A)^2$ with $c_1 > c_2$ at short R , and $c_2 > c_1$ at long R . The consequences of such a situation, were it to occur, are in the light of orbital symmetry constraints¹ obvious. There is created the likelihood of a sizable barrier to the symmetry-forbidden interconversion of the bond-stretch isomers I and II. Moreover, since the predominant electronic configurations

(2) At large separation it is clear that the single configuration molecular orbital description is inadequate. The wave function $c_1(S)^2 + c_2(A)^2$ describes the molecule better, with $c_2 > c_1$ as $R \rightarrow \infty$. At R_0 the (S)² configuration predominates.

of I and II differ we anticipate an entirely different set of characteristic chemical reactions for each.

Until recent times it was difficult to conceive that a simple bond stretching or angle bending could result in anything but the first case described above. This was the consequence of considering only direct through-space overlaps, which inevitably put the bonding, positive overlap, S combination at lower energy. More recently it has become abundantly clear that the interaction of formally localized orbitals with other framework levels can have effects rivaling in magnitude those of through-space overlap.³ These supplementary interactions, collectively called through-bond coupling, can reinforce, or, of greater significance to the case at hand, reverse the orbital pattern due to direct overlap.

We recently proposed that tricyclo[2.2.2.0]octane (3) might exist in two different conformations characterized by different electronic configurations, namely the strained propellane structure 3 and the stabilized dirad-

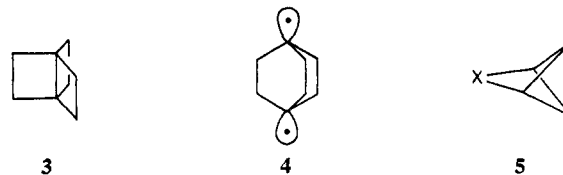

ical 4.⁴ Another example of potential bond-stretch isomerism, the tricyclo[2.1.0.0^{2,5}]pentane system 5, forms the subject of this paper.

Tricyclo[2.1.0.0^{2,5}]pentane and the (CH)₅⁺ Cation. The known molecules in the tricyclopentane series are derivatives of the parent hydrocarbon 6 and the ketone 7.⁵⁻⁷ Figure 1 shows the essential features of an extended Hückel⁸ calculation on 6.⁹ The C₁-C₅ distance

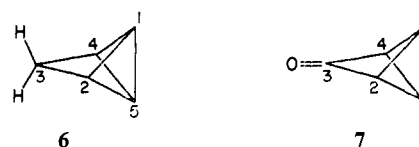

R is varied in this computation. At $R \sim 1.55$ Å we have a normal σ bond, a large gap between σ (symmetric, S, with respect to reflection in the 2-3-4 plane) and σ^* (antisymmetric, A). As R is stretched a level crossing occurs. We can trace this to a destabilization of the S combination by hyperconjugative interaction with C₂-C₃ and C₄-C₅ σ levels, as shown below.¹¹

(3) (a) R. Hoffmann, A. Imamura, and W. J. Hehre, *J. Amer. Chem. Soc.*, **90**, 1499 (1968); (b) R. Hoffmann, E. Heilbronner, and R. Gleiter, *ibid.*, **92**, 706 (1970); (c) J. R. Swenson and R. Hoffmann, *Helv. Chim. Acta*, **53**, 2331 (1970); (d) R. Hoffmann, *Accounts Chem. Res.*, **4**, 1 (1971).

(4) W.-D. Stohrer and R. Hoffmann, *J. Amer. Chem. Soc.*, **94**, 779 (1972).

(5) (a) S. Masamune, *ibid.*, **86**, 735 (1964); (b) S. Masamune and N. T. Castellucci, *Proc. Chem. Soc.*, 298 (1964); (c) S. Masamune, *Tetrahedron Lett.*, 945 (1965); (d) H. Ona, H. Yamaguchi, and S. Masamune, *J. Amer. Chem. Soc.*, **92**, 7495 (1970).

(6) (a) W. von E. Doering and M. Pomerantz, *Tetrahedron Lett.*, 961 (1964); (b) M. Pomerantz and R. N. Wilke, *ibid.*, 463 (1969).

(7) G. L. Closs and R. B. Larrabee, *ibid.*, 287 (1965).

(8) R. Hoffmann, *J. Chem. Phys.*, **39**, 1397 (1963); R. Hoffmann and W. N. Lipscomb, *ibid.*, **36**, 2179, 3489 (1962); **37**, 2872 (1962).

(9) The following idealized geometry was used for all values of R : C-C, 1.52; C₂-H, C₃-H, 1.09 Å; C₁-H, 1.08 Å; the hydrogens at C₁ and C₅ in planes 4-1-2 and 4-5-2, respectively; hydrogens at C₂ and C₄ along the 2-4 line. C₁-C₃ was kept at 1.90 Å. For a geometry of a substituted derivative of 6 see ref 10.

(10) (a) J. Trotter, C. S. Gibbons, N. Nakatsuka, and S. Masamune, *J. Amer. Chem. Soc.*, **89**, 2792 (1967); (b) C. S. Gibbons and J. Trotter, *J. Chem. Soc. A*, 2027 (1967).

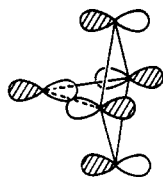

Though the level crossing is there, the secondary (A)² minimum occurs in a region of high strain and is weakly developed. Further stabilization must be supplied if this bond-stretch isomer is to be observed. An obvious goal is to stabilize the antisymmetric A combination at large *R*. This is accomplished by introducing an appropriately interacting antisymmetric acceptor orbital at C₃. The interaction diagram below shows the qualitative effects of an excellent acceptor of the proper symmetry type, a cationic center at C₃.

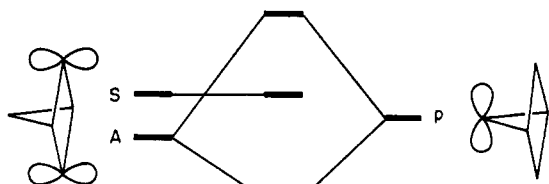
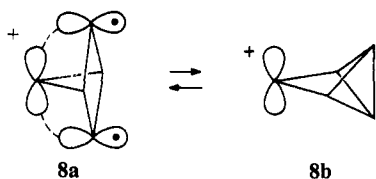
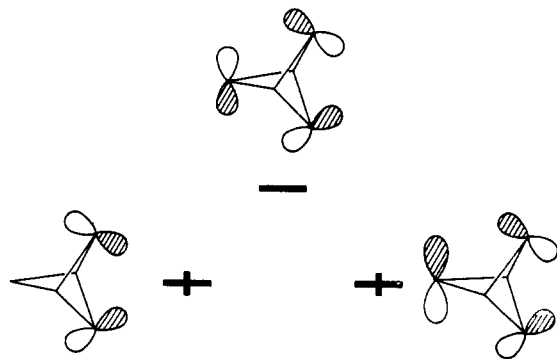

Figure 2, an extended Hückel calculation on the system **8a** ⇌ **8b**, confirms our analysis. At short *R* the



carbonium ion p orbital has little effect on the S and A orbitals of C₁-C₃.¹² At longer *R* it mixes drastically with the A level, and one A component sinks significantly below S. Note the avoided level crossing in Figure 2. The (A)² minimum, corresponding to the stabilized diradical **8a**, is now fully developed. While the relative stabilities of the two minima may not be reliably given by our calculations, we have little doubt that they are separated by a large barrier.

The high-energy point between **8a** and **8b**, the locus of the level crossing in Figure 2, occurs for a symmetrical *D*_{3h} geometry. The molecular orbitals at this point are indicated schematically below. Note that these



(11) For a related case see ref 3b.

(12) The acceptor orbital should strengthen the C₁-C₃ bond in this region (see ref 13). This is accomplished, however, by interaction with occupied A orbitals of the bicyclobutane, and not by affecting the S level responsible for C₁-C₃ bonding.

(13) (a) R. Hoffmann, *Tetrahedron Lett.*, 2907 (1970); (b) H. Günther, *ibid.*, 5173 (1970).

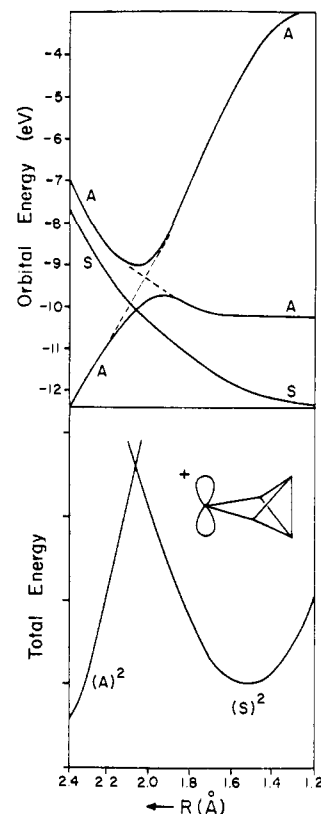

Figure 2. Highest occupied and two lower unoccupied MO's (top) and configuration energies (bottom) for stretching the 1-5 bond in **8b**. *R* is the 1-5 bond distance. The total energy scale interval is 1.0 eV.

have the very same shape as the well-known Walsh orbitals of cyclopropane. But unlike cyclopropane, where the degenerate pair is occupied, in the cation at hand we only have two electrons to place into these orbitals. It follows that the ground state of this conformation is likely to be a triplet, and that the lowest singlet will be subject to a Jahn-Teller distortion.¹⁴ This Jahn-Teller distortion is accomplished by reduction of the molecular symmetry from *D*_{3h} to *C*_{2v} in two possible ways—either to **8b** or **8a**. In either case the degeneracy is broken and a stabilized but less symmetrical singlet is formed.

The *D*_{3h} cation can distort to two *C*_{2v} forms in three equivalent ways, indicated in the Scheme I by dotted arrows. A glance at this pretty scheme reveals a fascinating possibility. The rearrangement of one isomer, say **8b**, to its open form **8a** need not take place through the high-lying *D*_{3h} transition-state **8c**. A circumvention is possible, as indicated by the solid arrows: **8b** → **8a'** → **8b''** → **8a**. The transition states intervening between the stable open or closed forms along this route are of *C*_s symmetry.

We pursued this digression into the area of carbonium ion rearrangements¹⁵ by calculating a potential energy surface for Scheme I. In an idealized geometry of the carbonium ion we varied independently the angles α and β defined below, with results shown in Figure 3.

(14) More exactly, a pseudo-Jahn-Teller effect. For a detailed treatment of this phenomenon consult L. Salem, "The Molecular Orbital Theory of Conjugated Systems," W. A. Benjamin, New York, N. Y., 1964, p 466 ff.

(15) Carbonium ion rearrangements of this class are reviewed by R. E. Leone and P. von R. Schleyer, *Angew. Chem.*, **82**, 889 (1970).

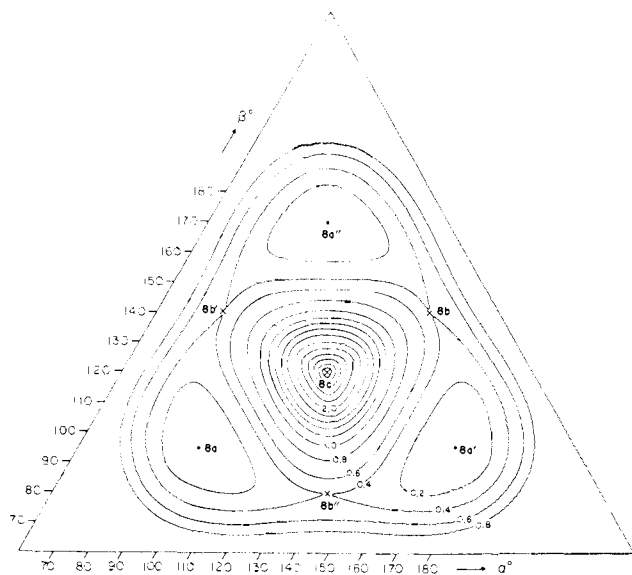
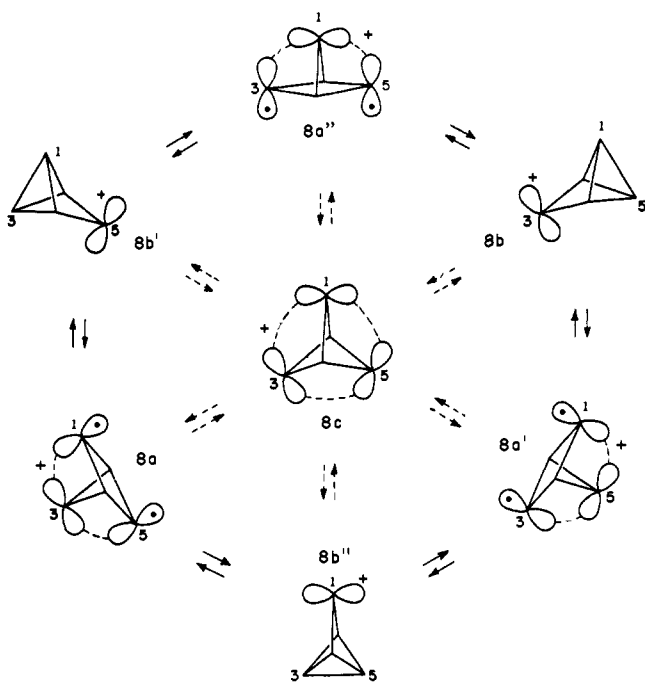

Figure 3. Potential energy surface for $(\text{CH})_5^+$, varying the angles α and β . The contour values are in electron volts, relative to an arbitrary zero at the geometry of the most stable point, **8a**.

Three minima are apparent, corresponding to the three identical open forms **8a**, **8a'**, **8a''**. The closed structures **8b**, **8b'**, and **8b''** do not in our calculations cor-

Scheme I



respond to energy minima, but are unstable with respect to a C_s distortion to the open forms. The D_{3h} geometry is clearly an energy maximum.

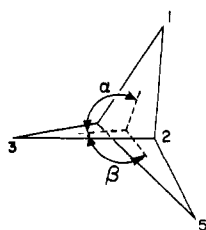

While our calculations indicate that the open forms **8a** are the minima and the closed structures **8b** transition states in this Jahn-Teller system we do not consider this result necessarily reliable. Extended Hückel calculations commonly fail to predict correct heats of formation, and hydrogen coordinates were not minimized at every point of the surface. The latter problem was partially studied. In the closed form ($\alpha = \beta = 140^\circ$) we allowed the hydrogens to leave the 2-1-4 and 2-5-4 planes. This motion gained a maximum of 0.15 eV for an out-of-plane angle of 15° (**9**). The analogous movement of hydrogens in the open geometry ($\alpha = \beta = 95^\circ$) gained 0.11 eV for an out-of-plane angle of 12° , in the direction shown in **10**.¹⁶

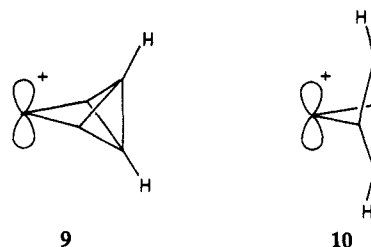

Whether the true minima for cation **8** correspond to the open or closed structures, there can be no doubt that we have at hand a dynamic Jahn-Teller system interconverting C_{2v} geometries **8a** and **8b** circumventing a higher energy D_{3h} transition state. *But the intricate web of carbonium ion rearrangements does not terminate here.*

We have previously chosen to view **8a** or **10** so to speak from the side. Another perspective is shown below in **11a**. It immediately suggests a CH^+ unit

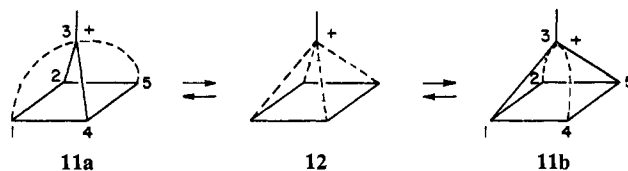

mounted above a C_4H_4 ring, and the possibility of a bond switching from **11a** to **11b**. This is a symmetry-allowed process! The demonstration is in the correlation diagram of Figure 4.

Not only is this interconversion allowed but we consider it likely that the transition state for this rearrangement, **12**, is more stable than its collapse products. **12** is a square pyramidal C_{4v} C_5H_5^+ . Some time ago one of us in collaboration with Lipscomb investigated the electronic structure of polyhedral $(\text{XH})_n$ species.¹⁷ For $X = \text{C}$ closed shell structures were obtained for tetrahedrane, cubane, and C_{4v} C_5H_5^+ . The electronic structure of this molecule is most easily perceived by the construction of an interaction diagram between cyclobutadiene and CH^+ (Figure 5). The ground-state configuration is $(a_1)^2(e)^4$. The analogy to the electronic structure of the well-known B_5H_9 is obvious.¹⁸

(16) Related puckering motions have been observed in the transition state for the Cope rearrangement (A. Brown, M. J. S. Dewar, and W. Schoeller, *J. Amer. Chem. Soc.*, **92**, 5516 (1970)) and trimethylene (Y. Jean and L. Salem, *Chem. Commun.*, 382 (1971)).

(17) R. Hoffmann and W. N. Lipscomb, *J. Chem. Phys.*, **36**, 2179 (1962).

(18) W. N. Lipscomb, "Boron Hydrides," W. A. Benjamin, New York, N. Y., 1963, p 80.

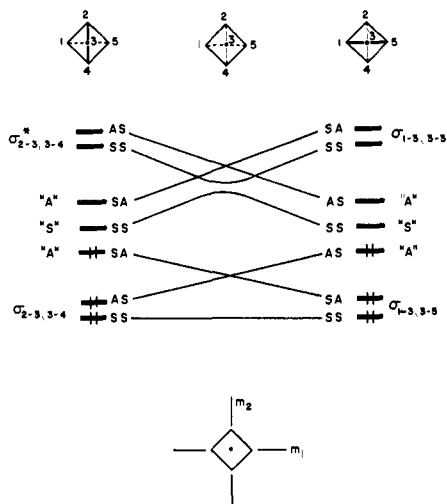
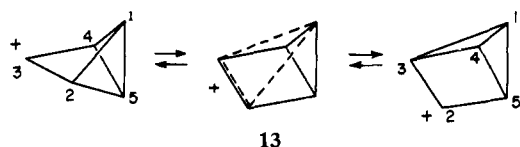

Figure 4. Level correlation diagram for the double bond switching of **11a** to **11b**. The mirror planes m_1 and m_2 used in the analysis are shown at bottom. The central set of orbitals, in quotation marks, refers to the interacting orbital system involving centers 1, 3, and 5 (at left) and 2, 3, and 4 (at right). See Figure 2 (top) and the accompanying discussion.

If a CH^+ approaches a cyclobutadiene whose CC bond lengths are 1.52 Å, an energy minimum is reached for a $C_{\text{apical}}-C_{\text{basal}}$ distance of 1.72 Å. We unfortunately cannot rely on extended Hückel comparisons of the stability of this C_{4v} species **12** relative to its possible collapse products **11**. A sizable energy gap of 5.5 eV separates HOMO from LUMO in **12**, ensuring a singlet ground state. We would guess that **12** is the energy minimum.

Another possible rearrangement of the closed form of the cation **8** is the cationic [1,2] sigmatropic shift shown below.¹⁵



The hypothetical transition state for this process, **13**, bears an obvious geometrical resemblance to the square pyramid **12**, and, though we have no computational evidence to support this, we think it also will collapse to a C_{4v} C_5H_5^+ .

There is still another aspect to this story. An alternate structure for C_5H_5^+ is a planar cyclopentadienyl cation **14**, $\text{R} = \text{H}$. While the parent antiaromatic

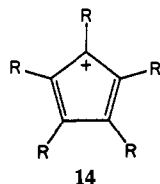

system is not known, derivatives with $\text{R} = \text{Cl}$ and $\text{R} = \text{phenyl}$ have been characterized.¹⁹ They exist either as ground-state triplets or as singlets with a very low-lying triplet state. We would like to suggest that the antiaromatic **14** singlet does not maintain the planar cyclopentadienyl structure, but rearranges to a square pyramidal geometry. The transformation could be

(19) (a) R. Breslow, H. W. Chang, and W. A. Yager, *J. Amer. Chem. Soc.*, **85**, 2033 (1963); (b) R. Breslow, R. Hill, and E. Wasserman, *ibid.*, **86**, 5349 (1964).

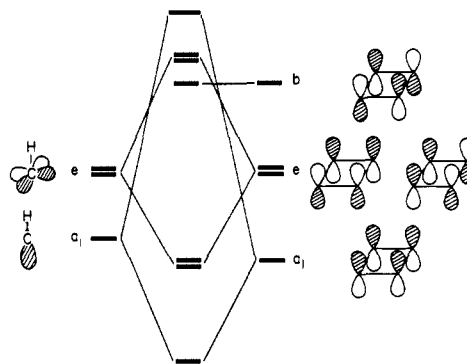
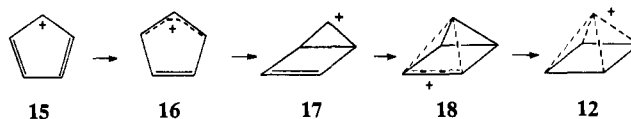
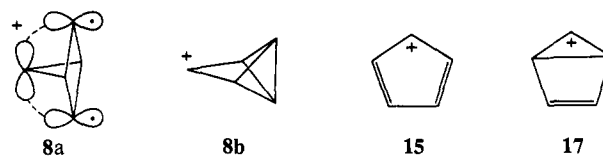

Figure 5. Interaction diagram showing how the orbitals of a C_{4v} $(\text{CH})_5$ are constructed from a CH and a cyclobutadiene. Note that this is *not* a correlation diagram for the approach of CH^+ to $(\text{CH})_4$.

shown sequentially as the allowed sequence **15** \rightarrow **16** \rightarrow **17** \rightarrow **18** \rightarrow **12**, with no implication that any of these representations are true energy minima. A double labeling experiment on **14** could provide the evidence for this rearrangement.



We summarize our conclusions concerning the $(\text{CH})_5^+$ system. While it is conceivable that structures such as **8a**, **8b**, **15**, or **17** could be local energy minima, we think this is unlikely and that the unique stable structure



in this system is the square pyramidal **12**. The multi-dimensional potential surface contains minima for 30 equivalent square pyramids, 15 pairs of enantiomers, with low-energy barriers to their interconversion. These transformations of one square pyramid into another one will *not* proceed *via* the $C_{4v} \rightarrow C_{2v} \rightarrow D_{3h} \rightarrow C_{2v} \rightarrow C_{4v}$ path shown below. Note the analogy of this path

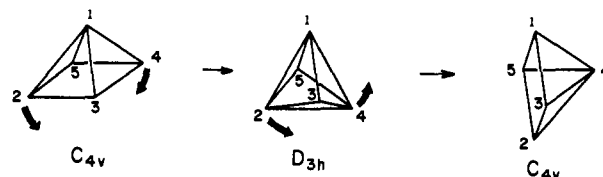

to the familiar Berry pseudorotation of pentavalent phosphorus.²⁰ Our calculations indicate that the probable paths of isomer interconversion should occur *instead via* the $C_{4v} \rightarrow C_s \rightarrow C_{2v} \rightarrow C_s \rightarrow C_{4v}$ sequence indicated below.

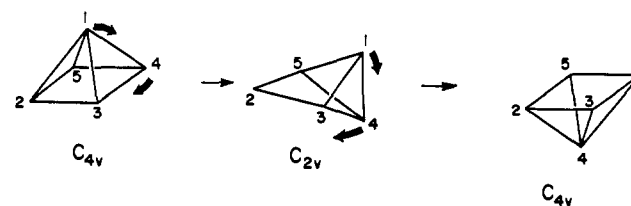

(20) R. S. Berry, *J. Chem. Phys.*, **32**, 933 (1960); reviewed by F. H. Westheimer, *Accounts Chem. Res.*, **1**, 70 (1968); E. L. Muettterties and R. A. Schunn, *Quart. Rev., Chem. Soc.*, **20**, 245 (1966); E. L. Muettterties, *J. Amer. Chem. Soc.*, **91**, 4115 (1969).

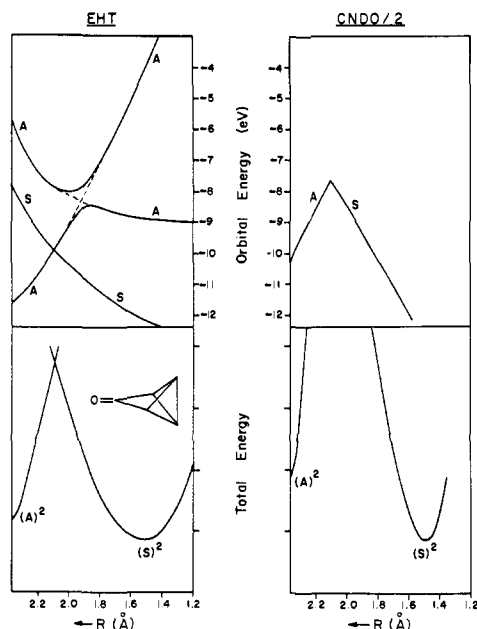
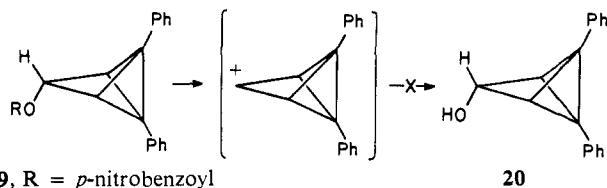

Figure 6. Highest occupied and lower unoccupied MO's (top) and configuration energies (bottom) for stretching the 1-5 bond in the tricyclopentanone **7**. R is the 1-5 bond distance. The total energy interval is 1.0 eV. The calculation at left is extended Hückel, at right CNDO/2.

The graph describing the possible sequence of such rearrangements may be easily written down,²¹ though it is sufficiently elaborate that little would be gained by presenting it here. Its salient features are the following. There are 30 C_{4v} isomers connected by a total of 60 rearrangements through C_{2v} transition states. The connectivity of the graph is 4, *i.e.*, there are four distinct rearrangement pathways leading from each square pyramid. The graph is closed,²¹ *i.e.*, it is possible by a sequence of rearrangements to traverse all stereoisomers. The minimal number of rearrangement steps to achieve a transformation of one isomer into its enantiomer is five.

In view of the intricate pattern of $(CH)_5^+$ rearrangements, it is a pity that so little is known experimentally about this species. Aside from the previously mentioned work on cyclopentadienyl cations¹⁹ we have found only a solvolysis study of **19**.^{22, 23} The product of the strongly accelerated solvolysis has apparently not been characterized, but it is not **20**. There is a hint, but no proof, of polytopal rearrangements in the study of Masamune and coworkers.²²



(21) A useful discussion of the topic of polytopal rearrangements may be found in E. L. Muettterties, *J. Amer. Chem. Soc.*, **91**, 1636 (1969). The polytopal rearrangements of carbonium ions have been extensively and elegantly studied by G. A. Olah and his collaborators. See G. A. Olah, *ibid.*, **94**, 808 (1972); G. A. Olah, Y. Halpern, J. Shen, and Y. K. Mo, *ibid.*, **93**, 1251 (1971), and references therein.

(22) S. Masamune, K. Fukumoto, Y. Yasunari, and D. Darwich, *Tetrahedron Lett.*, 193 (1966).

(23) The nmr spectrum of the 1,5-dimethyl derivative of **8** is under study at Case-Western Reserve University; M. Pomerantz (private communication).

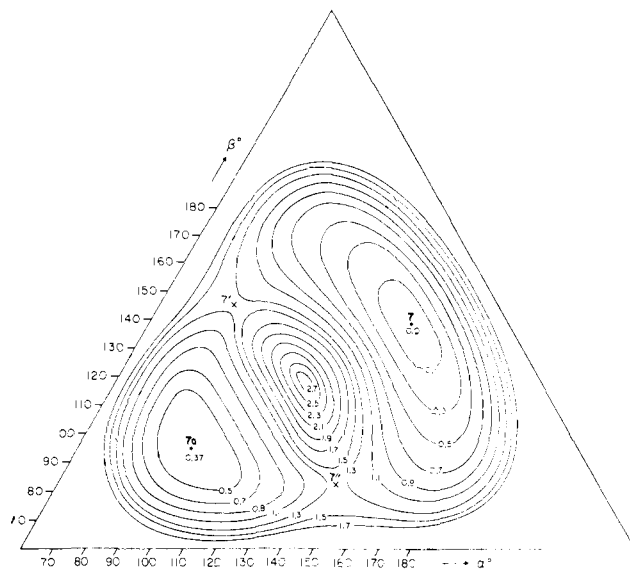
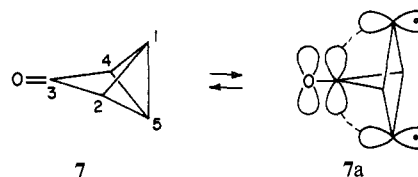

Figure 7. Potential energy surface for $(CH)_5CO$. The contour values are in electron volts, relative to an arbitrary energy zero at the geometry of the most stable point, **7**.

Tricyclo[2.1.0.0^{2,5}]pentanone. The title compound, unlike the $(CH)_5^+$ species, has the advantage of possessing known derivatives.^{5, 6} Like the cation it should exhibit two minima on C_1-C_5 bond stretching. In the ketone the antisymmetric acceptor orbital is the relatively low-lying π^* orbital of the carbonyl group. An open diradical, **7a**, should be stabilized.



We immediately confirmed this result by calculating a potential surface for the interconversion of **7** and **7a**, maintaining C_{2v} symmetry (Figure 6). In this case we obtained a further check on the extended Hückel results by performing a CNDO/2 calculation,²⁴ also shown in Figure 6. The results are similar. The predicted level crossing occurs, but now the closed isomer **7** is more stable than the open structure **7a**.

The complete surface for **7**, allowing α and β (defined above) to vary independently, is shown in Figure 7. While in many ways similar to the cation case, there are striking differences: (1) The closed tricyclopentanone **7** and the stabilized diradical **7a** are at the same points as the corresponding cation structures. But now the closed structure **7** is not only a true minimum but in fact the lowest energy point on the surface. (2) As in the $C_5H_5^+$ case the C_{2v} interconversion of **7** and **7a** is a high-energy process, and a circumvention is in order. But now there is little trace of the other open minima. These would have a geometry such as **21**, with no particular stabilization apparent. The closed geometries **7'** and **7''**, represented approximately by a zwitterionic structure, are not unexpectedly of higher energy than **7**. They indeed serve as transition states for the interconversion of **7** and **7a**. (3). The com-

(24) J. A. Pople, D. P. Santry, and G. A. Segal, *J. Chem. Phys.*, **43**, S129 (1965); J. A. Pople and G. A. Segal, *ibid.*, **43**, S136 (1965); **44**, 3289 (1966).

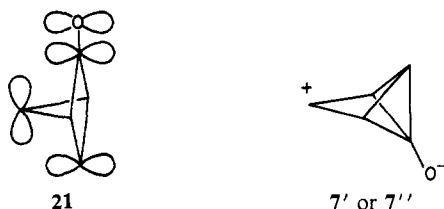

puted activation energy for the interconversion 7 to 7a via 7', when relaxation of selected hydrogen position was allowed, was 1.2 eV, while that for the reverse reaction was at least 0.85 eV. This implies that there is here a good chance of being able to observe the reactions of both bond-stretch isomers.

The preceding discussion of square pyramidal $C_5H_5^+$ suggests that the open structure 7a will symmetrize to the C_{4v} geometry 22. The interaction diagram for carbon

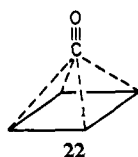

monoxide and cyclobutadiene resembles that for CH^+ and C_4H_4 . Now the HOMO of carbon monoxide, essentially a carbon axial lone pair, matches the role of the axial CH^+ lone pair, and the low-lying π^* orbital of CO takes the place of the p orbitals of CH^+ . 22 is essentially a carbonyl complex of cyclobutadiene.

From the point of view of polytopal rearrangements the perturbation of the symmetric $(CH)_5^+$ structure due to O^- substitution to $(CH)_4(CO)$ is so severe that it appears that of the $(CH)_5^+$ minima only six of the type of 22 remain. Several new minima corresponding to closed structures such as 7 appear. The surface becomes frozen, *i.e.*, the barriers between isomers are large.

We mentioned in the introductory statement that bond-stretch isomers, as a consequence of their differing electronic configurations, should have differing sets of allowed reactions. We can provide in the case of the open form of tricyclopentanone an illustration of this. The open form (22 as represented by 7a,) is a stabilized singlet diradical.²⁵ Its highest occupied MO is antisymmetric, 23, its lowest unoccupied symmetric, 24. Since the level ordering at the C_1-C_5 bond is

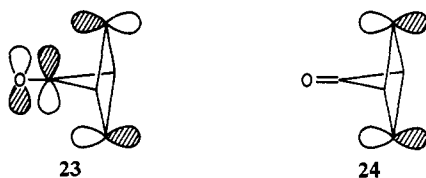

reversed from that of a normal σ or π bond²⁶ we would expect a reversal of the selection rules for cycloaddition at that bond. In particular the 2 + 2 cycloaddition of a double bond to 7a to form 25 is an allowed re-

(25) Our usage carries no implication of the spin state of the molecule. We term a diradical any molecule with two more or less nonbonding levels into which must be placed two electrons. For further discussion see: R. Hoffmann, S. Swaminathan, B. G. Odell, and R. Gleiter, *J. Amer. Chem. Soc.*, **92**, 7091 (1970); R. Hoffmann, *ibid.*, **90**, 1475 (1968); R. Gleiter and R. Hoffmann, *ibid.*, **90**, 5457 (1968); L. Salem and C. Rowland, *Angew. Chem.*, in press.

(26) Similar reversals have been found by us for 1,8-didehydronaphthalene: ref 3a; trimethylene, R. Hoffmann, *J. Amer. Chem. Soc.*, **90**, 1475 (1968); dimethylenephosphorane, R. Hoffmann, D. B. Boyd, and S. Z. Goldberg, *ibid.*, **92**, 3929 (1970).

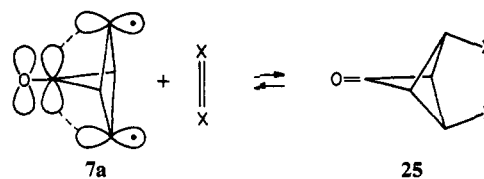

action. The reverse fragmentation could provide a route to the diradical.

Unfortunately, little is known concerning the chemistry of the tricyclic ketone 7 and what is known provides no indication of the presence of a stabilized diradical.

The known derivatives of the ketone all carry a pair of substituents at the 1 and 5 positions.^{5,6} The methyl derivative 26a fails to react with benzyne,²⁷ though

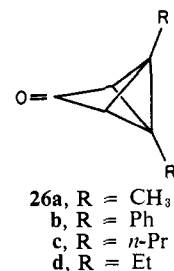

its open form should on theoretical grounds readily do so. 26a does undergo a cycloaddition with dimethyl acetylenedicarboxylate⁶ yielding dimethyl dimethylphthalates 27 and 28. The product ratio is temperature dependent and favors 28 at low tempera-

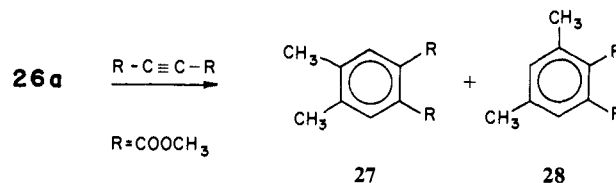

tures.^{6b} Evidence for an intermediate which reverts rapidly to 28 has been obtained.²⁸ This intermediate is not 29.

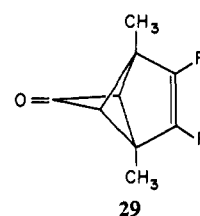

Dimethyl maleate and fumarate add readily to 26a to give 30 with stereochemistry preserved.^{5d} A similar reaction is observed with maleic anhydride or butadiene. These reactions were interpreted in terms of a

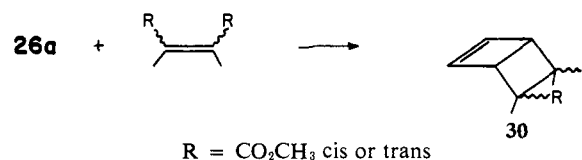

cyclobutadiene intermediate. Several alternative mechanisms could be written for some of the above cycloadditions, some of them involving the stabilized

(27) M. Pomerantz, G. W. Gruber, and R. N. Wilke, *ibid.*, **90**, 5040 (1968).

(28) M. Pomerantz, private communication.

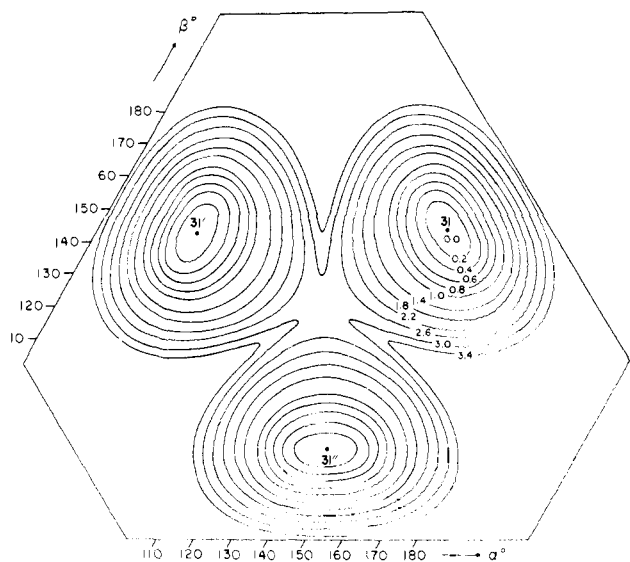
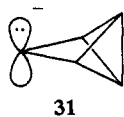

Figure 8. Potential energy surface for $(\text{CH})_5^-$. The contour values are in electron volts, relative to an arbitrary energy zero at the geometry of the most stable point, **31**.

diradical **7a**, and its cycloaddition product **29**. But, for the moment these must remain speculative.

The $(\text{CH})_5^-$ System. When two electrons are added to the $(\text{CH})_5^+$ molecule the Jahn-Teller system is so to speak quenched. Since both S and A orbitals (see Figure 2) are occupied, the traverse of the D_{3h} geometry no longer corresponds to a forbidden reaction. The closed structure analogous to **8b** now is the stable



point of the system, representing the anion **31**. The open form is no longer an energy minimum; neither is the square pyramidal structure. In a C_{4v} C_5H_5^- the extra electron pair would have to occupy an antibonding orbital (Figure 5).

A complete potential surface for $(\text{CH})_5^-$ is shown in Figure 8. It shows three equivalent minima for closed structures of the type of **31**, which can interconvert through the D_{3h} form. Though a stabilized longicyclic system,²⁹ the molecular geometry engenders no unexpected electronic features.

The continuity of the molecular orbital description of bonding in these molecules is demonstrated by a surface for $(\text{CH})_5^{3-}$. This surface, in which all three orbitals shown at the top of Figure 2 are occupied, has but a single minimum, a maximally symmetric D_{3h} structure. $(\text{CH})_5^{3-}$ is hardly a realistic molecule, but the isoelectronic 2,4,5-trioxabicyclo[1.1.1]pentane (**32**),

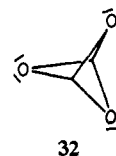

though to date unsynthesized, is structurally unexceptional. The predicted D_{3h} geometry here again touches base with our chemical intuition.

Acknowledgment. Our work was generously supported by the National Science Foundation (GP 28137) and the National Institutes of Health (GM 13468). The stay of W.-D. S. at Cornell was made possible through a fellowship from the Deutsche Forschungsgemeinschaft.

(29) M. J. Goldstein and R. Hoffmann, *J. Amer. Chem. Soc.*, **93**, 6193 (1971).